



Data Sheet

SVME/DMV-194

Freescale QorIQ™ P2020-based VME Single Board Computer



Features

- ◆ Freescale™ QorIQ™ P2020 up to 1.2 GHz
 - Two e500 processor cores
 - Each core has 64 KB L1 cache
 - 512 KB shared L2 cache with ECC
 - Single DDR3 memory controller with ECC
 - Three Gigabit Ethernet controllers
 - One USB port
 - Single DUART
 - Two I2C channels
 - One PCI Express® (PCIe) interface
 - Integrated DMA controllers
- ◆ Up to 4 GB DDR3 SDRAM with ECC in a single memory bank
- ◆ 512 MB NOR flash with write protection
- ◆ Optional 8 GB onboard NAND flash
- ◆ Permanent Alternate Boot Site (PABS) provides backup boot capability
- ◆ 512 KB FRAM
- ◆ IDT Tempe TS1148 VME64 master/slave interface with VME DMA (2esst capable)
- ◆ Three Gigabit Ethernet interfaces
 - 1 - Front panel - Standard product air-cooled only
 - 2 - Backplane
- ◆ Two XMC/PMC mezzanine sites
 - One site is 5 V tolerant, 133 MHz PCI-X PMC or 8-lane PCIe XMC
 - Second site is 3.3V tolerant, 100 MHz PCI-X PMC or 8-lane PCIe XMC
- ◆ Two asynchronous EIA-232 serial ports
- ◆ Up to 4 HDLC/SDLC-capable sync/async EIA-232/422/485 serial channels
- ◆ Up to 14 LVTTTL discrete I/O signals
- ◆ Up to 16 EIA-422/485 differential discrete signals (eight inputs, eight outputs)
- ◆ Multi-board synchronous clock
- ◆ Two channel MIL-STD-1553 option
- ◆ Two channel SATA 1.0 option
- ◆ Two USB 2.0 ports (one front panel, one backplane)
- ◆ Six general-purpose 32-bit timers in core functions FPGA
- ◆ Two 4-channel DMA engines
- ◆ Eight global timers organized as two groups of four in the P2020 Multi-core Programmable Interface Controller (MPIC)
- ◆ Two avionics-style watchdog timers
- ◆ Real Time Clock with +5V STDBY switch over
- ◆ Two temperature sensors
- ◆ Supports 5V only operations
- ◆ Continuum Software Architecture (CSA) firmware with extensive diagnostics
- ◆ Wind River® VxWorks® 6.8 Workbench® 3.x support
- ◆ Wind River® Linux® 4.x
- ◆ INTEGRITY® available from Green Hills Software
- ◆ Range of air- and conduction-cooled ruggedization levels available

Learn More

Web / sales.cwcembedded.com

Email / sales@cwembedded.com

ABOVE & BEYOND

**CURTISS
WRIGHT** Controls
Embedded Computing
cwembedded.com

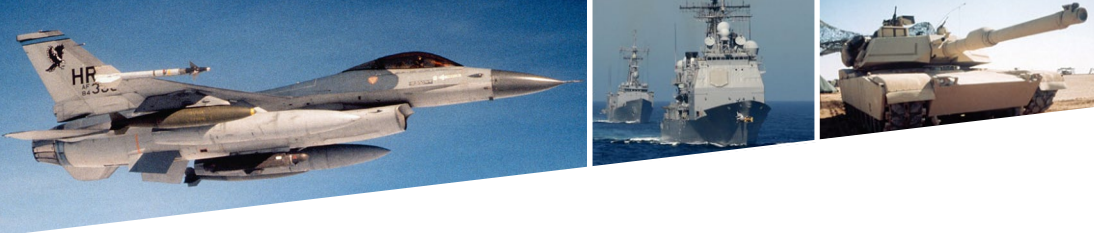

Overview

The VME-194 is the next generation of VME single board computer (SBC) from Curtiss-Wright Controls Embedded Computing. It is targeted for applications with moderate processing requirements, low power and cost effectiveness.

The VME-194 is based on Freescale's high-performance QorIQ™ P2020 SOC multi-core processor. The VME-194 provides high-performance processing, and a long list of features and I/O interfaces to satisfy the most demanding requirements of embedded computing.

Available in a full range of environmental build grades, the VME-194 is targeted to the control requirements for embedded systems in tactical aircraft, armored vehicles and harsh environment naval systems. For retrofit and technology insertion applications, the VME-194 offers a superset of the I/O features of earlier generations of Curtiss-Wright's VME 18x PowerPC® SBCs. As a member of Curtiss-Wright's continuously evolving product line of PowerPC SBCs including the SVME/DMV-179, 181, 182, 183, 184 and 186 the VME-194 supports the life-cycle model of successive technology insertions throughout a platform's lifetime.

The VME-194 will occupy a standard 0.8" slot.

Figure 1: SVME/DMV-194 Core Processing Architecture

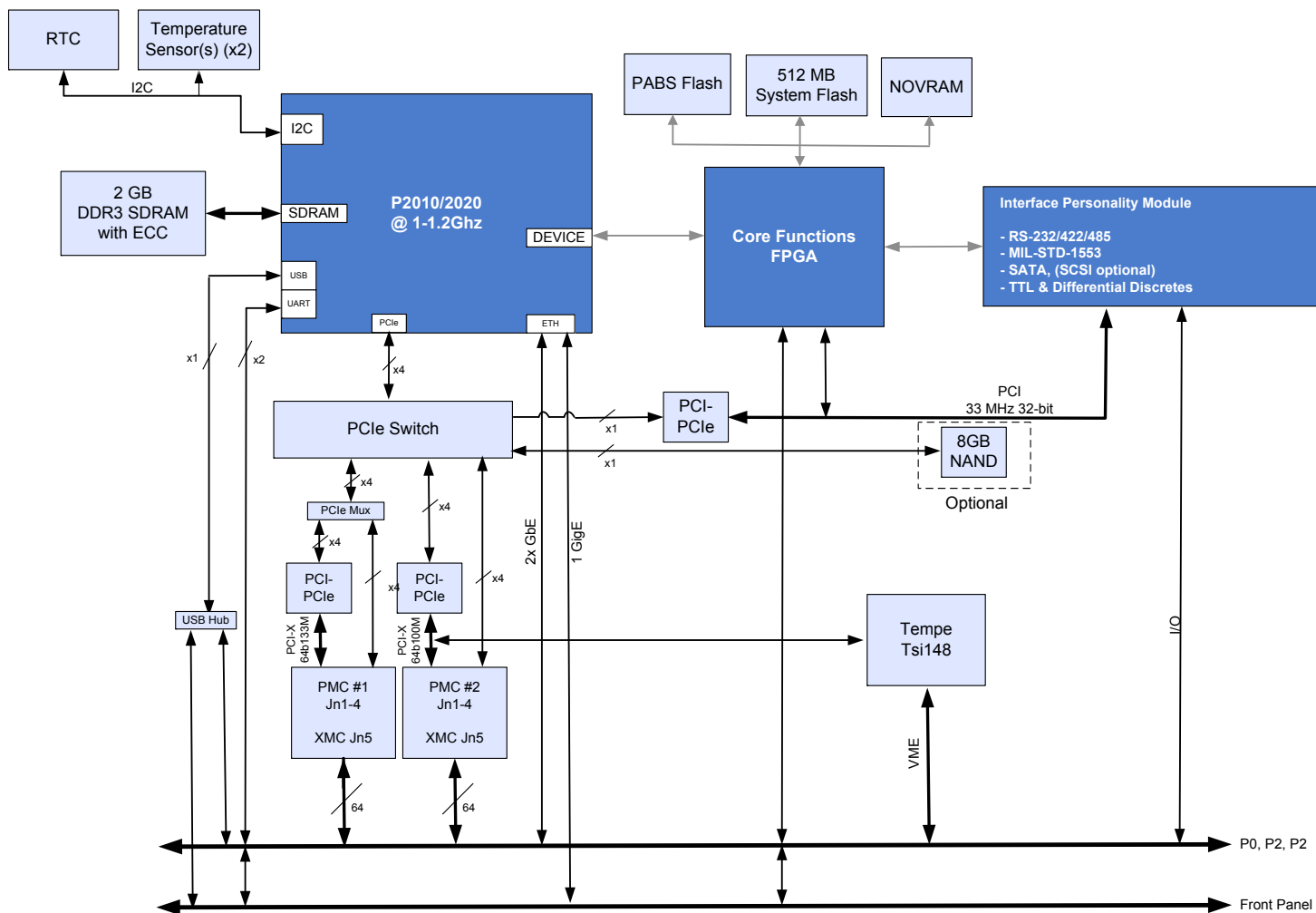



Dual Core Freescale™ Power Architecture™ QorIQ™ P2020 PowerPC

The processing function of the VME-194 is provided by the QorIQ P2020. The P2020 SOC includes the following functions and features used on the 194:

- ◆ Two e500 Power Architecture cores
 - Shared 512KB L2 Cache with ECC
 - 32 KB L1 instruction and 32 KB L1 data cache
 - Independent boot and reset
- ◆ Three 1 GbE controllers
- ◆ Single 64-byte DDR2/DDR3 SDRAM memory controllers with ECC
- ◆ Multi-core Programmable Interrupt Controller
- ◆ Two I2C controllers
- ◆ Two 2-pin UARTs
- ◆ Two 4-channel DMA engines
- ◆ Enhanced local bus controller (eLBC)
- ◆ Single PCI Express® (PCIe) 1.0 controller configured as a 4-lane port

Table 1 compares the key characteristics of the P2020 to the previous generation VME-186 SBC based on the P4080 processor.

Table 1: VME-194 to VME-186 Comparison

	194	186
Processor	Single P2020	Single P4080
Number Cores	Two e500 cores @ 1.2 GHz	Eight e500mc up to 1.5 GHz
Memory Banks	Single DDR3 at 800 MHz	Dual DDR3 at 1200 MHz
Memory Bandwidth (Max)	6.4 GB/s (DDR266)	17.05 GB/s (DDR600)
XMC Sites	Two x4 PCIe	Two x8 PCIe
PMC Sites	Two PCI-x	Two PCI-x
I/O Routing		
XMC/PMC Site	64 PMC IO (PN4)	64 PMC IO (PN4)
XMC Sites	-	-

Double Data Rate (DDR3) SDRAM

The VME-194 has one DDR3 memory controller supporting a single bank of DDR3 SDRAM. The VME-194 may be fitted with 1 GB, 2 GB or 4 GB of DDR3 SDRAM. The DDR3 interface operates at a rate up to 800MHz resulting in a peak bandwidth of 6.4 GB/s.

To preserve data integrity, the SDRAM is provided with ECC circuitry that detects and corrects all single-bit data errors, detects all double-bit errors, and detects all 1-bit and 2-bit errors within the same nibble. The SDRAM is accessible from the processor, VME and PCIe interfaces. Subject to the configuration of BSP settings controlling the memory management of the P2020 processor, the memory can be accessed from the local XMC/PMC devices and VME.

NOR Flash Memory

The VME-194 is available with 512 MB of flash memory. The flash will retain data for 20 years at +85°C, assuming that the sector containing the data has less than 1,000 erase cycles. The data retention drops as erase cycle count increases. After 10,000 cycles, data retention is for 10 years. After 100,000 cycles, data corruption will likely be noticeable in one year. Read performance of the flash array is optimized in order to minimize system boot up time for applications such as avionics mission computers where fast restarts after power interruptions are critical.

For absolute security against inadvertent flash programming or corruption, a hardware jumper is provided to disable writing to flash. The CSA firmware of the VME-194 provides flash programming functions with support for downloading flash images over Ethernet. See the separate CSA firmware data sheet for details. See the Non-volatile Memory Security section for more information on write protection and scrub features.

NAND Flash

The VME-194 can be optionally configured with 8 GB of NAND flash through a SATA interface.



Permanent Alternate Boot Site (PABS)

PABS provides a backup boot capability in the event that the firmware in the main flash becomes corrupted. This can occur because of an error during reprogramming or an incorrect image being loaded. PABS provides users with a convenient mechanism to recover from corruption of the main NOR flash without removing the card from the system in which it is installed. An on-board jumper and a backplane signal (ALT_BOOT) are provided to cause the card to boot from PABS, thus allowing a user to reinstall the standard firmware load. The PABS feature guarantees that a card will never need to be removed from a system to perform NOR flash updates.

FRAM

A Ramtron FM22L16 Ferroelectric Random Access Memory (FRAM) provides 512 KB of fast, non-volatile storage of mission state data that must not be lost when power is removed. FRAM reads and writes like standard SRAM and as with all FRAM devices, writes occur at bus speed and are immediately non-volatile. The FRAM memory is non-volatile due to its unique ferroelectric memory process which means that data is retained after power is removed. It provides data retention for over 10 years. Fast write timing and high write endurance make FRAM superior to other types of memory. The FM22L16 includes a low voltage monitor that blocks access to the memory array when VDD drops below a critical threshold. The memory is protected against inadvertent access and data corruption under this condition. The device also features software-controlled write protection.

Non-volatile Memory Security

The VME-194, as well as other Curtiss-Wright Continuum Architecture products, provides for the management of non-volatile memory devices in classified circumstances. All of the non-volatile devices, flash, PABS flash, FRAM and FPGA PROM may be individually write-protected by a hardware jumper. The jumpers may be visually inspected to conform to security procedures. The CSA firmware of the VME-194 provides non-volatile scrub functions to perform a secure erase per NISPOM requirements.

The VME-194 I/O System

The VME-194 features a large number of I/O interfaces including EIA-232, EIA-422/485 serial, USB, Ethernet, MIL-STD-1553, SATA, TTL and differential discrete I/O. The VME-194 provides for an I/O expansion facility with the inclusion of the Interface Personality Module (IPM). The IPM concept, carried forward from the VME-182, 183, 184 and 186 SBCs as well as the VPX6-185 and 187, is a connectorized subassembly that can either simply provide physical-level transceivers for controller devices implemented in the core functions FPGA, or it can host PCI peripherals such as a SATA interface device. Some of the optional I/O features are implemented with IPM modules. Refer to Table 2 for a summary of the I/O configurations that are available on the VME-194.

VME Interface

The VME-194 is equipped with a VME master/slave interface that supports the VME64x, 2eVME, and 2eSST protocols. The interface is implemented with the IDT's Tsi148 PCI-X to VME bridge. The Tsi148 supports the newest 2eSST VMEbus transfer protocol offering the maximum possible VME performance, while retaining full backwards compatibility with legacy VME systems. The VMEbus can be mapped into the memory space of the P2020, and similarly transfers from VME can be destined for the VME-194 local SDRAM. The Tsi148 features internal DMA engines to move data between local memory and the VMEbus. The VME-194 can also be ordered without the Tsi148 installed for customers interested in reduced cost and power.

Gigabit Ethernet Interface

The VME-194 is equipped with up to three 10/100/1000 Base-T Ethernet interfaces, all implemented within the P2020. One Ethernet is 10/100/1000Base-T capable and configured only to the front panel connector. The second Ethernet is also 10/100/1000 Base-T capable and is routed to the P0 connector. The third Ethernet is connected to the P2 connector and is either 10/100BaseT or 10/100/1000Base-T capable depending on the particular IPM installed - see Table 2. The Ethernet controllers integrate a number of features designed to minimize processor loading due to Ethernet traffic. These include dedicated DMA engines, support for jumbo packets up to 9 KB, efficient buffer management schemes, checksum calculation for IP, TCP, and UDP, and interrupt coalescence.



Dual Serial ATA (SATA) Interface Option

The VME-194 optionally provides two SATA 1.0 (1.5 Gb/s) interfaces based on the Silicon Image 3124 device. Each interface incorporates several performance-enhancing features such as:

- ◆ Independent DMA channel with 2K FIFO
- ◆ Independent command fetch, scatter/gather, and command execution

See Table 2 for configurations that include SATA.

Four EIA-232 Serial Ports

All VME-194 configurations have two EIA-232 serial channels. These are routed to the backplane and the front panel in air-cooled variants. The EIA-232 serial ports (channels 1, 2) support asynchronous communications with one transmit and one receive signal. One serial port supports the use of the DTR signal to automatically detect the connection of a data terminal and can be used to control the boot-up sequence of the card if desired. The two serial ports are implemented with the P2020's DUART. The baud rate of all four ports can be set independently from 300 to 115200.

Four EIA-232/422/485 Serial Port Option

The VME-194 is available in configurations with one, two or four additional serial ports (channel numbers 3-6). These additional serial ports are implemented with a 85230 Serial Communication Controller (SCC) core in both the core functions FPGA for all of the IPM modules, and the FPGA on the Mode 6 serial IPM. All of the serial ports support asynchronous communication with baud rates of 300-115200. All of the serial ports support synchronous HDLC/SDLC communications at up to 2.0 Mb/s. In synchronous mode a full range of data encoding schemes are supported (NRZ, NRZI Mark, NRZI Space, FM0, FM1, Manchester, and Differential Manchester). The synchronous ports support separate transmit and receive clock signals and can use internal or external clocking, or clock encoded schemes. All of the serial ports support software selection of either EIA-232 (async only) or EIA-422/485 (sync or async) signal levels. See the Differential Discrete I/O section below for information on how the VME-194 provides the

capability to control each of the EIA-422/485 drivers and receivers as differential-mode discrete signals for use as serial control signals or general purpose I/O. See Table 2 for configurations that include the optional 232/422/485 serial channels.

LVTTTL Discrete Digital I/O Option

The VME-194 optionally provides 14-bits of LVTTTL compatible discrete digital I/O. Each bit is individually programmable to be an input or output. Each I/O bit is capable of generating an interrupt upon a change of state, with programmable edge detection. The output drive current is 24mA. See Table 2 for configurations that include the optional DIO signals.

Differential Discrete Digital I/O

The VME-194 provides the capability to control each of the EIA-422/485 drivers and receivers as differential-mode discrete signals via registers in the core functions FPGA. This allows flexibility in how the drivers and receivers are used. The choice of whether the drivers and receivers are attached to serial ports or used as discrete differential I/O is software selectable on a per-serial channel basis. When configured as discrete differential I/O, the drivers and receivers can be used as serial-line control signals (RTS, CD, etc.) in conjunction with another serial channel, or used as general-purpose differential mode control signals unrelated to serial I/O requirements. Differential discrete inputs can generate an interrupt upon a change of state, with programmable edge direction. Note that if the serial channel physical levels are set to EIA-232, then discrete digital I/O at EIA-232 levels is obtained.

Two USB 2.0 Ports

The VME-194 provide two USB ports. The one USB port from the P2020 goes thru a USB bridge to provide a USB port to the front panel and another to the backplane. In the conduction cooled variant, the bridge is removed and USB goes directly to the backplane.

One USB port is accessible on the front panel connector (air-cooled only) and the other is accessible on the P0 connector. Each port provides a +5 V output to power external USB devices such as keyboards.



Table 2: Summary of I/O Options

Mode	Front Panel (air-cooled only)	P0 Connector	P2 Connector
0 (standard product)	<ul style="list-style-type: none"> Serial 1, EIA-232 Serial 2, EIA-232 USB port 2 Card reset push button Serial 7, EIA-232 Serial 8, EIA-232 	<ul style="list-style-type: none"> PMC site #1 I/O ENETP0 (GbE) USB 2 Carfail status out Card reset input ALT_BOOT input No TTL discrete I/O 	<ul style="list-style-type: none"> PMC site 2 I/O (rows A & C) ENETP2 (10/100) Serial 1, EIA-232 Serial 2, EIA-232
6 (standard product)	Same	Same as Mode 0 plus 14 TTL discrete I/O	<ul style="list-style-type: none"> PMC site 2 I/O (rows A & C) ENETP2 (10/100) Serial 1, EIA-232 Serial 2, EIA-232 Serial 3, EIA-232/422/485 Serial 4, EIA-232/422/485 Serial 5, EIA-232/422/485 Serial 6, EIA-232/422/485
8 (by customer specific request)	Same	Same as Mode 0 plus 14 TTL discrete I/O	<ul style="list-style-type: none"> PMC site 2 I/O (rows A & C) ENETP2 (GbE) Serial 1, EIA-232 Serial 2, EIA-232 Serial 3, EIA-232/422/485 Serial 4, EIA-232/422/485 MIL-STD-1553 #1
9 (standard product)	Same	Same as Mode 0 plus 14 TTL discrete I/O	<ul style="list-style-type: none"> PMC site 2 I/O (rows A & C) ENETP2 (GbE) Serial 1, EIA-232 Serial 2, EIA-232 Serial 3, EIA-232/422/485 Serial 4, EIA-232/422/485 MIL-STD-1553 #1 MIL-STD-1553 #2
10 (standard product)	Same	Same as Mode 0 plus 14 TTL discrete I/O	<ul style="list-style-type: none"> Same as Mode 9 but only no MIL-STD-1553
11 (standard product)	Same	Same as Mode 0 plus 14 TTL discrete I/O	<ul style="list-style-type: none"> PMC site 2 I/O (rows A & C) ENETP2 (GbE) Serial 1, EIA-232 Serial 2, EIA-232 Serial 3, EIA-232/422/485 Serial 4, EIA-232/422/485 MIL-STD-1553 #1 SATA #1 SATA #2
12 (standard product)	Same	Same as Mode 0 plus 14 TTL discrete I/O	<ul style="list-style-type: none"> Same as Mode 11 but without MIL-STD-1553



Two Channel MIL-STD-1553 Option

The VME-194 provides up to two MIL-STD-1553 channels implemented with DDC 65864 micro-ACE TE devices offering the following key features:

- ◆ Support for MIL-STD-1553A, MIL-STD-1553B Notice 2, and STANAG 3838 protocols
- ◆ BC, RT, MT modes independently selectable for each channel
- ◆ Choice of transformer-coupled (standard) or direct-coupled outputs (on a special order basis)
- ◆ MIL-STD-1760 amplitude compliant (optional)
- ◆ 64K words of RAM per channel, with parity
- ◆ PCI interface is 33 MHz, 32-bit and supports burst writes with a FIFO for up to one complete MIL-STD-1553 message
- ◆ Transmit Inhibit input for each channel
- ◆ Bus Controller features:
 - Highly autonomous bus controller with built-in message sequence control engine for multi-frame message scheduling, branching, and asynchronous message insertion
 - Programmable inter-message gap size
 - Single frame or auto-repeat modes
 - Automatic retries
 - Time-tag can be transmitted with Synchronize with Data mode code
 - External Trigger input for each channel
- ◆ Remote Terminal features
 - Programmable illegalization of RT commands
 - Busy bit programmable on a sub-address basis
 - 16-bit time-tag option with options of 2, 4, 8, 16, 32, or 64 μ sec/LSB based on internal clock
 - External Time-tag Clock Input
 - Time-tag can be set via Synchronize with Data Mode Code
 - External Subsystem Flag Input
- ◆ Monitoring Terminal features
 - Selective message monitor mode, use for selecting monitoring based on RT address, Transmit/Receive bit, and Sub-address
 - Simultaneous RT and monitor modes The RT address for each channel can be set by software

A backplane configuration input is provided for each channel that can cause the RT address to be set by a subset of the

TTL discrete digital I/O lines. To meet the MIL-STD-1760 First Response requirement of an RT response within 150msec, one of the MIL-STD-1553 channels initializes as an RT with the Busy status word bit set. This requires that the MIL-STD-1553 channel be configured to set the RT address in hardware.

Curtiss-Wright's driver software for the VME-194's MIL-STD-1553 channels provides a flexible, easy to use, and robust applications programming interface (API). The driver supports BC, RT, and MT modes of operation, and offers a high-degree of compatibility to the proven software driver provided for Curtiss-Wright's popular PMC-601 MIL-STD-1553 module. Source code is provided for user reference. The MIL-STD-1553 driver for the VME-194 is sold separately from the hardware and the VME-194 BSPs.

Real-Time Clock (RTC)

A Maxim/Dallas Semiconductor DS3231 RTC chip provides the RTC function. It contains registers for century, year, month, day, hours, minutes, and seconds. The RTC is capable of generating alarm interrupts. The RTC draws its power from +5 V. In the event of loss of backplane +5 V power, the RTC will automatically switch over to draw power from the backplane +5V STDBY.

Extensive Timing Resources

The VME-194 provides a large number of timing resources to facilitate precise timing and control of system events. The list of available timers is shown in Table 3.

Avionics Watchdog Timers

The VME-194 provides two watchdog timers. Each watchdog timer is a presettable down-counter with a resolution of 1 μ sec. Time-out periods from 1 msec to 33 seconds can be programmed. Initialization software can select whether a watchdog exception event causes a software interrupt, a processor reset, a card reset or a system reset. Once enabled to cause a reset, the watchdog cannot be disabled. A watchdog event indicator discrete signal is output to the backplane.

The watchdog timer can be used in two ways. As a standard watchdog timer, a single time period is programmed which defines a maximum interval between writes to the watchdog register. For increased system integrity, the watchdog can optionally be configured to operate in "Avionics" mode whereby a minimum interval between writes to the watchdog register is also enforced. In other words, writing to the watchdog register too soon or too late causes an exception event.



General Purpose DMA Controllers

The P2020 provides two 4-channel DMA controllers that are available for general purpose use. The DMA controller can be used for transferring blocks of data between the SDRAM, flash memory, device bus peripherals, and the PCI busses. Direct and descriptor-driven chained operation are supported, as are source and destination striding. The DMA controllers also feature a bandwidth management feature to allow the user to control the distribution of bandwidth between the four DMA channels.

XMC/PMC Sites

The VME-194 is equipped with two adjacent mezzanine sites. Both mezzanines are capable of supporting an IEEE 1386 PMC or VITA 42.3 XMC module with 64-bits of Pn4 I/O backplane connectors, as per VITA 35.

On conduction-cooled cards, the XMC/PMC sites adhere to the VITA 20- 2001 (R2005) conduction-cooled PCI Mezzanine Card (PMC) standard specifications. To optimize the thermal transfer from XMC/PMC modules to the base card, the standard VME-194 thermal frame incorporates both the Primary and Secondary thermal interfaces as defined by VITA 20-2001.

The VME-194 is capable of hosting Processor PMCs in non-Monarch mode as described in the VITA 32-2003 draft standard (the Monarch# signal is pulled to VIO). The VME-194 does not support the optional second PCI agent, the optional EREADY signal, or the optional RESETOUT# signal.

Table 4 provides details on the capabilities of both mezzanine sites.

Table 3: VME-194 Timing Resources

Timer	Implementation	Type	Size	Tick Rate/Period	Maximum Duration
PowerPC Time Base Register	One per CPU	Free Running Counter	64-bit	125 MHz/8 nsec	4,676 yrs
PowerPC Decrementer	One per CPU	Presettable, Readable Downcounter	32-bit	125 MHz/8 nsec	34.35 sec
General Purpose #0-7	P2020 MPIC	Presettable, Readable Downcounter with auto-read and stop options, divide by 8, 16, 32 and 64	32-bit	Divide 16	114 sec
RTC Alarm	RTC	Alarm Interrupt	-	-	-
Watchdog timers	Core Functions FPGA	Presettable, Readable Downcounter with interrupt or reset on terminal count	25-bit	1 MHz/1 usec	33.55 sec
System Timers #1-6	Core Functions FPGA	Presettable, Readable Downcounter with interrupt on terminal count	32-bit	50 MHz/20 nsec	85.9 sec

Table 4: VME-194 PMC/XMC Specifications

Function	Site 1	Site 2
Location	Top of card	Middle of card
PCI Interface	<ul style="list-style-type: none"> PCI-X 64-bit 100 MHz via 4-lane PCIe/PCI bridge Shared with TS148 	PCI-X 64-bit 133 MHz via 4-lane PCIe/PCI bridge
PCIe Interface	<ul style="list-style-type: none"> Up to 8-lane per VITA 42.3 2 GB/s peak simultaneous transmit and receive 	<ul style="list-style-type: none"> Up to 8-lane per VITA 42.3 2 GB/s peak simultaneous transmit and receive
Pn4 I/O	64-bits mapped as per VITA35	64-bits mapped as per VITA 35
VIO	3.3 V only	Jumper select for 3.3 V or 5 V
3.3 V Power	<ul style="list-style-type: none"> Provided from onboard PSU, 13 W maximum to any one site 16.5 W total maximum The 3.3 V is sequenced with the main board power 	
5.0 V Power	<ul style="list-style-type: none"> Drawn from backplane 5.0 V 20 W maximum to any one site, 30 W maximum total The 5 V is sequenced with the main board power 	



Status Indicators and Controls

The VME-194 SBC provides run/fail status by asserting a backplane signal and illuminating a red front panel LED in the event the diagnostics detect a card failure. There is also a software controlled green LED that the application can use to indicate status of CPU cores. A card reset signal is available on the backplane connectors and on the front panel connector on air-cooled cards. The front panel cable for the VME-194 includes a push button switch that interfaces to this signal to allow the card to be reset without doing a full system reset.

Debug Interfaces

For debugging purposes, the VME-194 provides an onboard header for access to the P2020 COP port. Customers can order a cable to interface between the onboard COP header and the traditional COP interface.

For use of a COP emulator with the VME-194, consult Curtiss-Wright.

Temperature Sensors

The VME-194 provides two sensors to measure board and processor temperatures.

Designed for Harsh Environments

To cost-effectively address a diverse range of military/aerospace applications, the VME-194 is available in a range of ruggedization levels, both air- and conduction-cooled. All versions are functionally identical, with air-cooled versions (SVME) available in Curtiss-Wright's ruggedization Levels 0 and 100, and conduction-cooled versions (DMV) in Levels 100 and 200. Air-cooled level 200 is available on a special order basis. Curtiss-Wright's standard Ruggedization Guidelines define the environmental tolerance of each ruggedization level (see Curtiss-Wright Ruggedization Guidelines factsheet for more information).

Enhanced Thermal Management for Conduction-Cooled Applications

For those demanding application environments that require conduction-cooling, the SVME/DMV-194 uses a combination of thermal management layers within the Printed Wiring Board (PWB) and an aluminum thermal frame that provides a cooling path for the PMC sites and for high-power components such as the processors, caches, and bridge device. The VME-194 thermal frame employs a number of innovative design techniques to keep the temperature rise of the electronic components to a minimum, thus increasing the long-term reliability of the product:

- ◆ Provision of both primary and secondary thermal interfaces on PMC sites
- ◆ Mid-plane thermal shunts for mezzanine sites
- ◆ TherMax design approach

Figure 2: Representative Thermal Frame

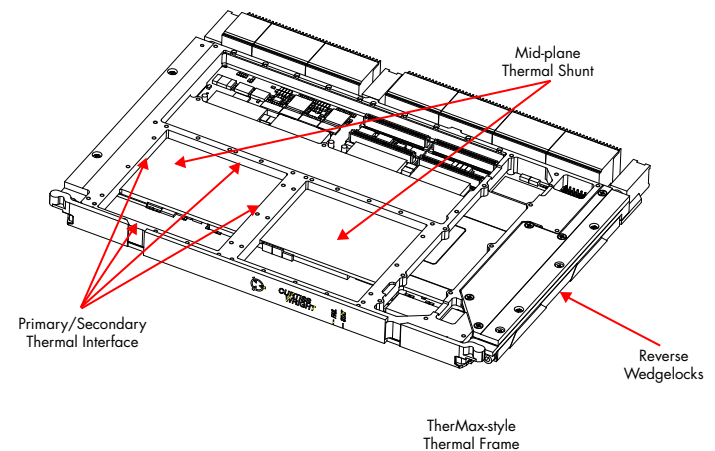

Mid-plane Thermal Shunts for PMCs

To optimize the conduction-cooling of high-performance, high-power PMC modules such as graphics or networking PMCs, the VME-194 thermal frame incorporates mid-plane thermal shunts for the PMC sites. High-power PMCs can include a mating cooling surface on the PMC module to contact the mid-plane thermal shunt. By taking advantage of the thermal shunt, suitably designed PMC modules can significantly lower the heat rise from the VME-194 card edge to the PMC components. The midplane thermal shunt does not impinge on the VITA 20- allowed component height.



TherMax-style Thermal Frame

A TherMax thermal frame provides an unbroken metallic path from the PMC sites and shunted components to the back-side cooling surface of the card therefore minimizing the temperature rise to these devices. In comparison, a typical thermal frame simply sits on top of the PWB and forces heat to flow through the PWB, which has a high thermal resistance compared to aluminum.

Figure 3: Typical Thermal Frame

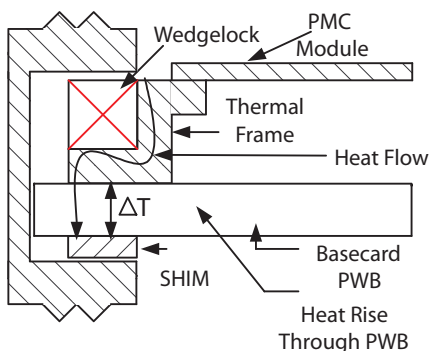
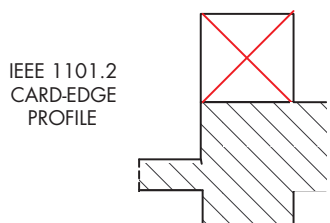

Figure 4: Card-edge Profile Deviates from IEEE 1101.2

VME-194 Card-Edge Profile is Optimized to Provide a Full-width Thermal Interface to the Back-side Slot Wall



Software Support

Continuum Software Architecture (CSA)

The VME-194 is supported by a suite of firmware, RTOS BSPs, communication libraries and signal processing libraries. The Continuum Software Architecture is Curtiss-Wright's suite of firmware and BSP APIs common to SBCs (VME, CPCI and VPX) and multi-processor boards. Developers of mixed systems will find a common set of features and software interfaces for all future processing products from Curtiss-Wright. The Continuum Software Architecture is comprised of:

Continuum Firmware Monitor

The monitor provides a command line interface over serial port or Ethernet to allow a user to perform a variety of system integration activities with the card. The monitor provides debug and display commands, diagnostic results display and exerciser controls, non-volatile memory programming and declassification and programming of parameters used to control boot-up and diagnostics.

Continuum Built-in Test (BIT)

BIT is a library of diagnostic routines to support Power-up BIT (PBIT), Initiated BIT (IBIT), and Continuous BIT (CBIT) designed to provide 95% fault coverage.

Operating System Software

The VME-194 is supported with an extensive array of software items, which cover all facets of developing application code for the board. Users have the option of choosing to develop with a variety of operating systems and development tools. The following operating systems are supported or planned for the VME-194:

- ◆ Wind River® VxWorks® 6.8+ SMP Workbench® 3.x Part Number DSW-194-0106-CD
- ◆ Wind River® Linux® (4.x) - Part Number: DSW-194-6400-LNX
- ◆ INTEGRITY available from Green Hills Software



Cable Set

Table 5 provides details on the various development I/O cables available for the SVME/DMV-194. These cables are common with previous generation Curtiss-Wright VME cards - 182/183/184 and 186.

Table 5: VME-194 Cables

Cable Number	Connects To	Description
CBL-184-FPL-000	Front panel in all pin-out modes	Front panel break-out cable for SVME-184 providing two 9-pin D connectors for EIA-232 ports, one RJ-45 jack for GbE, one USB type A receptacle, and one push-button reset switch.
CBL-182-P0-000	P0 in all pin-out modes	P0 break-out cable for 182/183/184 in all pin-out modes. Provides RJ-45 Jack for 10/100/1000Base-T Ethernet interface, 25-pin female D connector for TTL discretes, USB type A receptacle for USB port 2, and PMC I/O on 78-way connector. Also includes reset switch.
CBL-183-P2-000	P2 in pin-out Mode 0 (no IPM)	P2 break-out cable for 182/183/184 in pin-out Mode 0. Provides separate branches and connectors for two 9-pin D connectors for EIA-232 ports, RJ45 jack for Ethernet, and 18x-standard 78-way connector for PMC I/O.
CBL-183-P2-006	P2 in pin-out Mode 6	P2 breakout connector for 181/182/183/184 in pin-out Mode 6. Provides two 9-pin D connectors for EIA-232 ports, four 25-pin D connectors for EIA-422/485 ports, RJ45 jack for Ethernet, and 18x-standard 78-way connector for PMC I/O.
CBL-183-P2-009	P2 in pin-out Mode 8 and 9	P2 break-out for 182/183/184 in Mode 8 (single MIL-STD-1553) and Mode 9 (dual MIL-STD-1553). Provides separate branches and connectors for the transformer-coupled MIL-STD-1553 signals, MIL-STD-1553 configuration inputs, two EIA-232 ports, two EIA-232/422/485 ports, RJ-45 jack for Ethernet, and PMC I/O on 18x-standard 78-way connector. Connectors for MIL-STD-1553 signals are 3-lug Twinax bulkhead jack connectors, Trompeter part number BJ79-47.
CBL-182-P2-010	P2 in pin-out Mode 10	P2 break-out for 182/183/184 in Mode 10. Provides separate branches and connectors for two EIA-232 ports, two EIA-232/422/485 ports, GbE, and PMC I/O on 78-way connector.
CBL-183-P2-011	P2 in pin-out Mode 11	P2 break-out cable for 183/184 in Mode 11. Provides separate branches and connectors for one MIL-STD-1553 channel, MIL-STD-1553 configuration inputs, two EIA-232 ports, two EIA-232/422/485 ports, GbE, two SATA ports, and PMC I/O on 78-way connector. Connectors for MIL-STD-1553 signals are 3-lug Twinax bulkhead jack connectors, Trompeter part number BJ79-47.
CBL-183-P2-012	P2 in pin-out Mode 12	P2 break-out cable for 183/184 in Mode 12. Provides separate branches and connectors for two EIA-232 ports, two EIA-232/422/485 ports, GbE, two SATA ports, and PMC I/O on 78-way connector.
CBL-186-JTAG	VME-186 JTAG COP Cable	Connects to 186 test connector and provides standard 2x8 .1" pitch header for JTAG/COP emulators. Can also be used on the VPX6-187.



Power Consumption

See Table 6 for power consumption for the VME-194 standard product variant base-cards. Power consumption increases as operating temperature rises.

The VME-194 is designed to run off 5 V, and does not draw current from the other voltage rails for normal operation. Hence, power consumption in the table below is for 5 V only. The PMC site always draws power from the 5 V rail. The XMC site is provided with VPWR (+5 V).

See Table 8 for power consumption for the IPMs available with the VME-194.

Table 6: Variant Power Requirements

Ruggedization Level	Part Number	Reference Configuration	Max Typical Power (W)
Level 0 Air-cooled	SVME-194-0000	P2020 @ 1.2 GHz 2 GB DDR3 512 MB NOR ACO	TBD
Level 100 Air-cooled	SVME-194-1000	P2020 @ 1.2 GHz 2 GB DDR3 512 MB NOR AC100	TBD
Level 200 Conduction-cooled	DMV-194-2000	P2020 @ 1.2 GHz 2 GB DDR3 512 MB NOR C200	TBD

Notes:

1. Typical power is measured power while running stress test software that exercises CPU and board functions. The actual power consumption observed will vary by application.
2. For thermal design considerations, Curtiss-Wright recommends adding 5% to the typical power consumption. For power supply sizing, Curtiss-Wright recommends adding 20% to the typical power consumption.

Table 7: Typical Maximum Current Requirements

Voltage	Ruggedization Level	Max Typical Current Amps	Comments
+5	Level 0	TBD	
	Level 100/200	TBD	
+3.3 V	All levels	0	Not used
+/-12 V	All levels	0	Only routed to PMC sites
+5V STDBY	All levels	50 ma	

Notes:

1. For thermal design considerations, Curtiss-Wright recommends adding 5% to the typical power consumption. For power supply sizing, Curtiss-Wright recommends adding 20% to the typical power consumption.

Table 8: IPM Power Requirements

Ruggedization Level		Typical Power (Watts) (see note)
All	Mode 6 IPM	2
All	Mode 9 IPM with both MIL-STD-1553 channels at 50% Tx time	5
All	Mode 9 IPM with both MIL-STD-1553 channels at 25% Tx time	3
All	Mode 11 IPM with MIL-STD-1553 channels at 50% Tx time	4
All	Mode 11 IPM with MIL-STD-1553 channels at 25% Tx time	3
All	Mode 12 IPM	2

Notes:

1. For thermal design considerations, Curtiss-Wright recommends adding 5% to the typical power consumption. For power supply sizing, Curtiss-Wright recommends adding 20% to the typical power consumption.

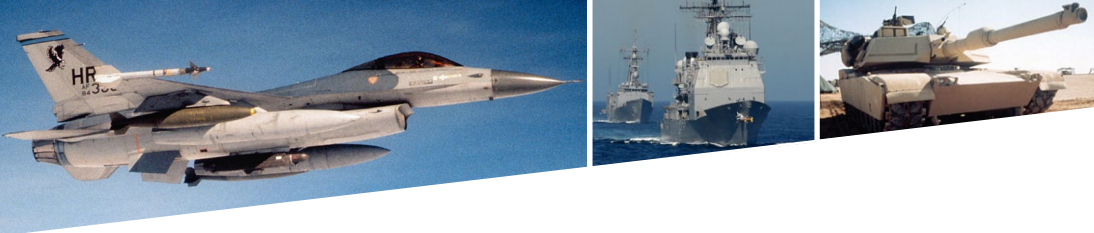

Specifications

The tables below show the power, dimensions and weight characteristics of the card.

Table 9: VME-194 Dimensions and Weight

Option	Dimensions	Weight (grams)
Air-cooled 0.8" Level 0	per ANSI/VITA 1-1994	TBD <500
Air-cooled 0.8" Level 100	per ANSI/VITA 1-1994	TBD <500
Conduction-cooled	per IEEE 1101.2**	TBD <800
IPM	-	39(max)

Notes: The air-cooled format is designed to fit chassis with 0.8" slot.

Table 10: SVME-194 Cooling Requirements

Configuration	Temperature Range	Air Flow (CFM)
P2020 up to 1.2 GHz	-40°C to 71°C	TBD

Notes: Air-flow is specified for sea-level conditions. The temperature refers to the inlet temperature at the card. The air-flow specifications are for worst case (highest power) conditions, without any PMC/XMCs installed. Curtiss-Wright can supply additional recommendations for specific power/temperature/altitude scenarios and pressure drop characteristics of the VME-194 support the design and testing of cooling subsystems.

Ruggedization Levels

Air-cooled cards are available in Levels 0 and 100.

Conduction-cooled cards are available in conduction-cooled Levels 100 and 200. See the Curtiss-Wright Ruggedization Guidelines fact sheet for more information. Level 100 is via customer's specific request only.



Ordering Information

The VME-194 is ordered with the following part numbers. Not all possible configurations are offered. Consult Curtiss-Wright for available configurations.

Options in bold will be available as standard product with following limitations:

- ◆ Contact factory for other variants
- ◆ All others available as customer specific variants with CM Service
- ◆ Level 100 Conduction-cooled will be available as customer specific variants

SVME/DMV - 194 - xyz

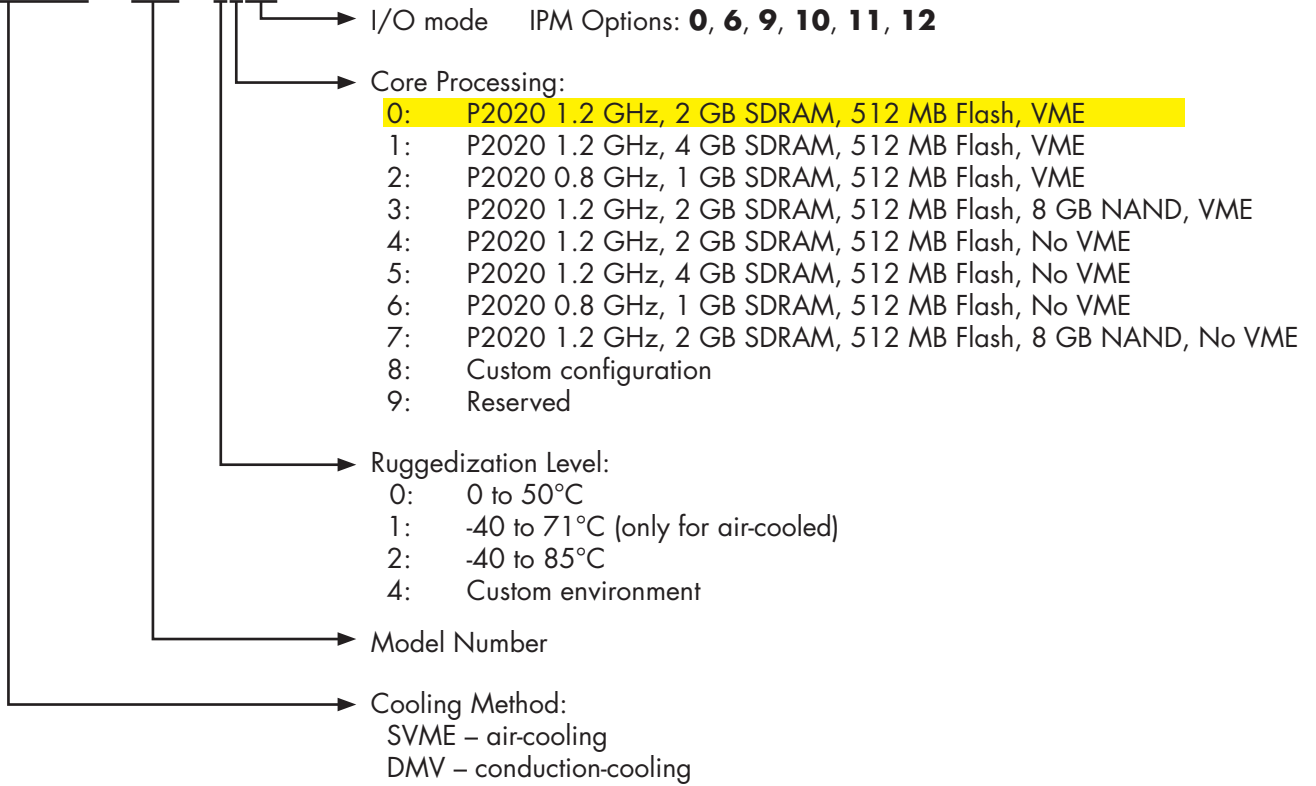

Warranty

This product has a one year warranty.

Contact Information

To find your appropriate sales representative:

Website: www.cwembedded.com/sales

Email: sales@cwembedded.com

Technical Support

For technical support:

Website: www.cwembedded.com/support

Email: support1@cwembedded.com

The information in this document is subject to change without notice and should not be construed as a commitment by Curtiss-Wright Controls Embedded Computing. While reasonable precautions have been taken, Curtiss-Wright assumes no responsibility for any errors that may appear in this document. All products shown or mentioned are trademarks or registered trademarks of their respective owners.

UNITRONIX Pty Ltd

PO Box 486, Morisset NSW 2264

NSW: Tel: 61 2 4977 3511 Fax: 61 2 4977 3522

WA: Tel: 61 8 9455 2424 Fax: 61 8 9455 2458

unitsyd@unitronix.com.au www.unitronix.com.au